



# Quantum DXi6802 and DXi690x: Drive Replacement

---

For DXi6802 or DXi690x systems with DXi 2.3 Software or later, Quantum recommends using the Drive Replacement utility to replace a failed drive. The utility will guide you through the replacement process. To begin, navigate to **Utilities > Diagnostics > Drive Replacement** in the DXi remote management console.

Alternately, follow the steps in this document to replace a failed drive in your DXi6802, DXi6902, DXi6900 G1/G2 (see [Figure 1](#)) or DXi6900-S system (see [Figure 2](#)).

- [Step 1: Overview](#) on page 3
- [Step 2: Prepare for Removal](#) on page 3
- [Step 3: Replace Drive](#) on page 5
- [Step 4: Rebuild](#) on page 7



Figure 1 DXi6802/DXi6902/  
DXi6900 G1/G2 Disk Layout

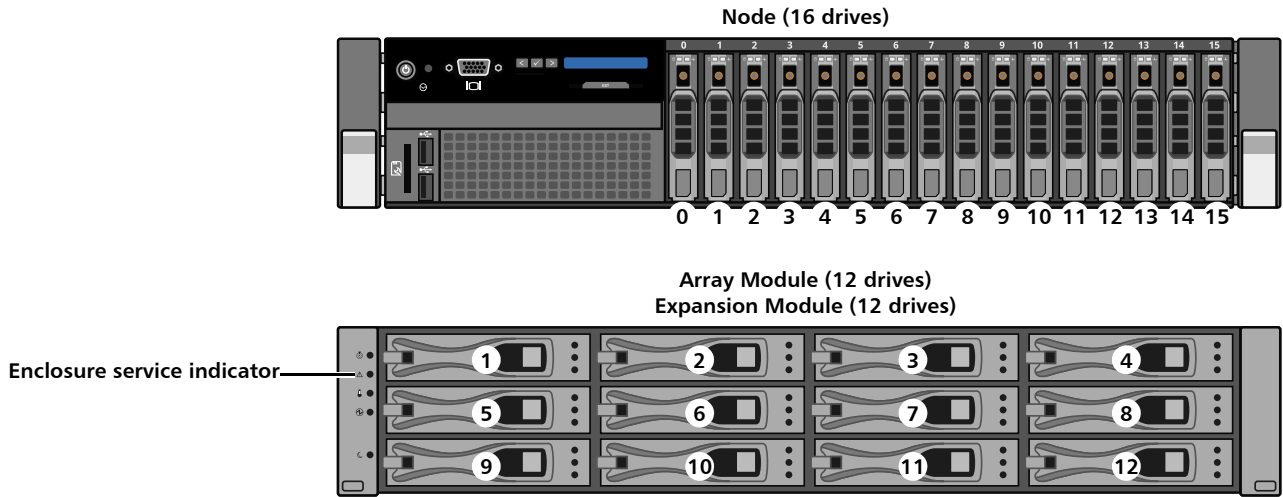
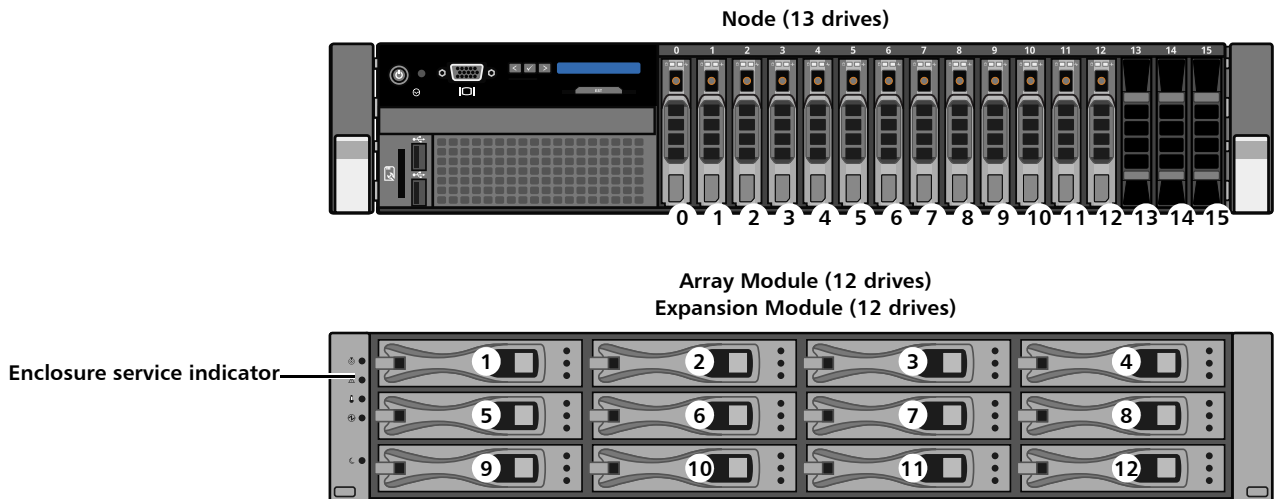

Figure 2 DXi6900-S Disk  
Layout



---

## Step 1: Overview

Before you begin the drive replacement procedure, review the following information:

- You can perform this procedure only if there is a single failed drive in the DXi. If there are multiple drive failures, contact Quantum Support.
- Use only the Quantum-supplied replacement drive to perform the replacement procedure. Do *not* use any other drive (not even one taken from another DXi).
- The drives in the DXi are hot-swappable. Do *not* power down the DXi system to replace the failed drive.
- Installing the replacement drive will take approximately 30 minutes.
- After the replacement drive is installed, the drive rebuilding process automatically begins and takes approximately three hours (Node drive) or seventeen hours (Array or Expansion module drive), depending on system load. You may use the DXi normally while the drive rebuilds, but system performance may be reduced.

---

**Caution:** Do *not* remove the failed drive completely from the DXi until instructed to do so. If you remove the failed drive but do not insert a replacement drive within a few minutes, the enclosure may overheat.

---

---

**Caution:** Make sure to remove only the failed drive from the DXi. If you remove a drive that has not failed, multiple service tickets will occur. Re-insert the drive, and then contact Quantum Support.

---

---

## Step 2: Prepare for Removal

To prepare the failed drive for removal:

- 1 If you are using the Drive Replacement utility, wait for the drive status to change to **Failed--Ready For Removal** before continuing.

---

**Note:** (DXi6802/DXi6902/DXi6900 G1/G2 Only) After the drive fails, it takes about 3 hours for the status to change to **Failed--Ready For Removal**. During this time, the DXi is copying data to one of the hot spare drives to ensure integrity of the volume.

---

- 2 Locate the failed drive by observing the status LEDs on the front of each drive carrier in the DXi (see [Figure 3](#) and [Figure 4](#)).
  - **Note** - While the Drive Replacement utility is open, the drive status indicator on the failed drive will be blinking green.

If you exit the Drive Replacement utility, the drive status indicator on the failed drive will be blinking amber.

- **Array or Expansion Module** - While the Drive Replacement utility is open, the drive failure indicator on the failed drive will be blinking amber. Also, the drive service indicator will be solid blue.

If you exit the Drive Replacement utility, the drive failure indicator on the failed drive will be solid amber. Also, the drive service indicator will be solid blue.

In addition, in all cases, the enclosure service indicator on the left side of the Array or Expansion module will be solid amber (see [Figure 1](#)).

---

---

**Caution:** Do *not* remove a drive if its green drive activity indicator displays any activity.

---

---

---

**Note:** You can remove the bezel from the Node if you have trouble viewing the LEDs.

---

Figure 3 Drive Carrier LEDs - Failed Drive (Node)

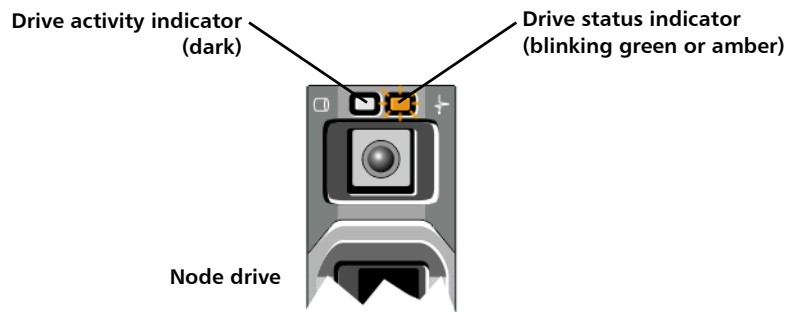
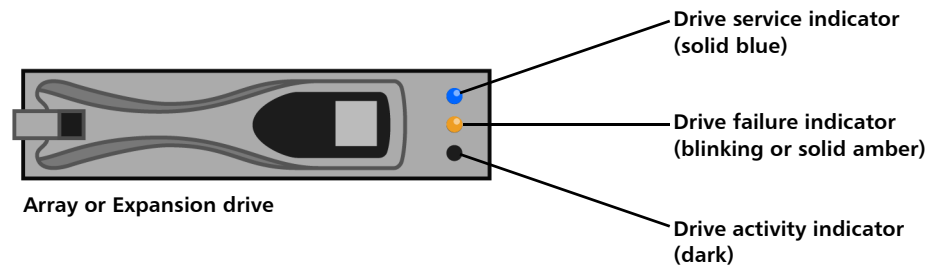

Figure 4 Drive Carrier LEDs - Failed Drive (Array or Expansion Module)



- 3 If the failed drive is in the Node, remove the bezel from the front of the Node if you have not already done so.
- 4 Do one of the following:
  - **Node** - On the failed drive carrier, press the release button to extend the handle (see [Figure 5](#)).
  - **Array or Expansion Module** - On the failed drive carrier, pull the handle to extend it (see [Figure 6](#)).
- 5 Grasp the handle and pull the failed drive carrier outward 1 inch only. **Do not pull the drive completely from the enclosure at this time.**

- 6 If you are using the Drive Replacement utility, wait for the drive status to change to **Missing**. (This will take up to 4 minutes, so be patient.)

Figure 5 Preparing a Drive for Removal - Node

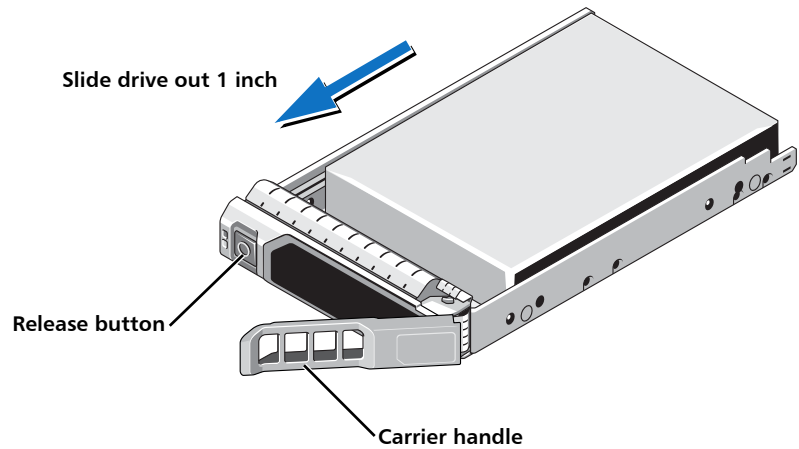
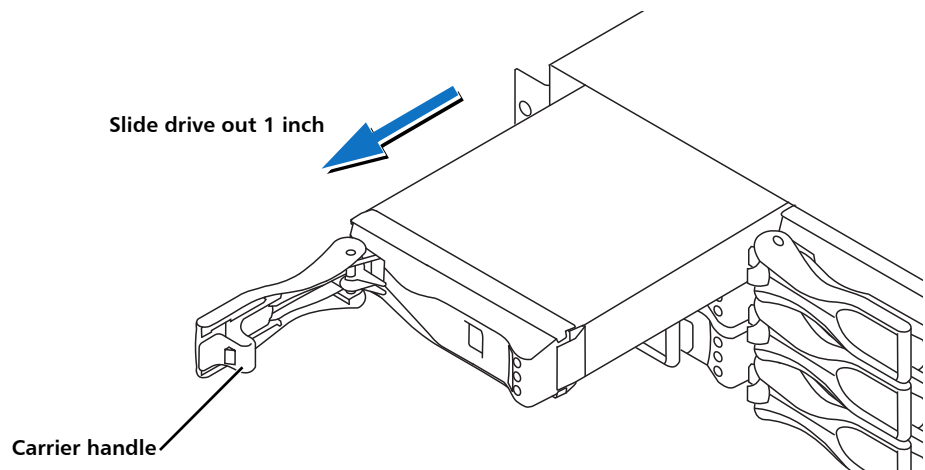

Figure 6 Preparing a Drive for Removal - Expansion Module



## Step 3: Replace Drive

---

**Note:** When replacing Array or Expansion module drives, there must be a minimum 30 second delay between removing the failed drive and installing the replacement drive.

---

To install the replacement drive:

- 1 Unpack the replacement drive.
- 2 Slide the failed drive carrier out until it is free of the drive bay and set it aside.

- 3 Hold the replacement drive carrier in one hand, and with your other hand touch an exposed metal surface on the rack where the DXi is installed to discharge any static electricity buildup.
- 4 Do one of the following:
  - **Node** - On the replacement drive carrier, press the release button to extend the handle.
  - **Array or Expansion Module** - On the replacement drive carrier, pull the handle to extend it.
- 5 Insert the replacement drive carrier into the drive bay and push it in all the way (see [Figure 7](#) and [Figure 8](#)).
- 6 Close the drive carrier handle to lock the drive in place.
- 7 If you are using the Drive Replacement utility, wait for the progress bar to display, indicating the rebuilding process has begun. (This will take up to 5 minutes, so be patient.)

---

**Note:** If the progress bar does not display after 5 minutes, remove the drive, wait 1 minute, and then re-insert it, making sure the drive is pushed in all the way.

---

Figure 7 Replacing a Drive - Node

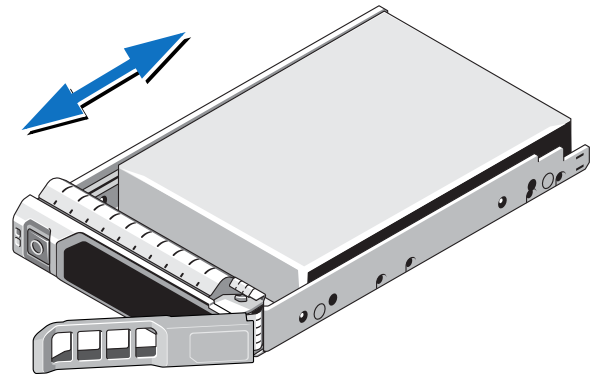
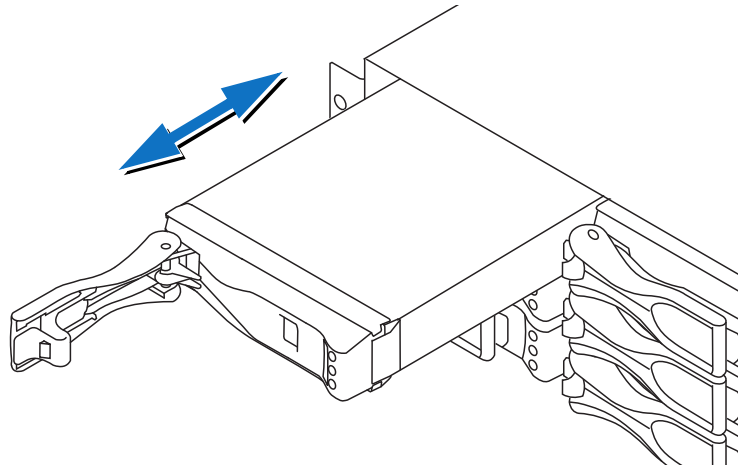

Figure 8 Replacing a Drive -  
Expansion Module



## Step 4: Rebuild

Use the status LEDs on the replacement drive to monitor the rebuilding process (see [Figure 9](#) and [Figure 10](#)):

- **Node** - The status indicator for all drives in the Node will blink green while the drive is rebuilding.

---

**Note:** If the replacement drive is a hot spare drive, no rebuilding process is needed.

---

- **Array or Expansion Module** - The activity indicator for all drives in the Array or Expansion module will blink green while the drive is rebuilding.

The drive rebuild process takes approximately three hours (Node drive) or seventeen hours (Array or Expansion module drive), depending on system load. During the rebuild process, the remote management console displays **Normal** state in the system banner, and you may use the DXi normally.

Figure 9 Drive Carrier LEDs -  
Rebuilding (Node)

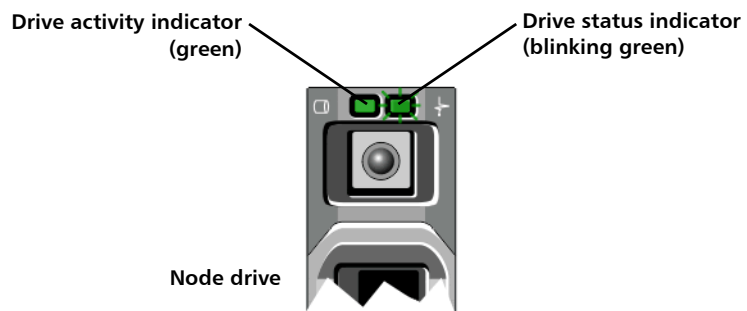
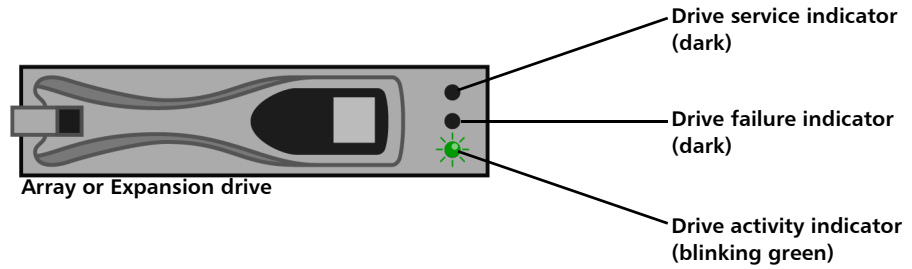

Figure 10 Drive Carrier LEDs -  
Rebuilding (Array or Expansion  
Module)



If you are using the Drive Replacement utility, when the progress bar reaches 100%, the drive replacement process is complete, and you can exit the utility.

---

**Note:** Don't forget to reinstall the bezel on the front of the Node if you removed it.

---

---

**Note:** Don't forget to return the failed drive to Quantum for proper credit (follow the instructions included with the replacement drive).

---